

Tooling catalog
For TRUMPF punching machines
Ver. 01/2015 ENG
Rotation | Standard tools



This catalog is used only for machine types:

Group 1:

TRUMATIC 190R,
TRUMATIC 200R,
TRUMATIC 500R,
TRUMATIC TC 600L (LASERPRESS)

Group 2:

TRUPUNCH 1000R,
TRUMATIC 1000R,
TRUPUNCH 2000R,
TRUMATIC 2000R,
TRUMATIC 2020R,
TRUMATIC 3000R,
TRUPUNCH 3000,
TRUPUNCH 5000,
TRUMATIC 5000R,
TRUMATIC 3000 fiber,
TRUMATIC 6000,
TRUMATIC 7000 (Laser Punch)
and all new machine series



For all other TRUMPF models and machines please contact us or refer to our other catalogs. It means that the tooling which is used for machines of Group 1 and 2 (Rotation machines) could be not suitable for other models of TRUMPF machinery or machines from other manufacturers which use TRUMPF Style tooling.

Please do not use this catalog if your machine doesn't belong to the Group 1 or 2 or contact us.

Our tools normally are completely suitable with the tools of other manufacturers which mean you can buy only the wear elements you need (punches, dies, strippers etc.) Anyway we kindly ask you to inform what the tooling you use now to prevent any problems.

If you use the tool from other manufacturer, you can just provide us the original codes in your request and we will be able to make you the full offer according to the original codes.

The present document doesn't contain any information about forming tools and special forms. Please contact us to get more information.

Standard tools

Standard round	AT3
Standard square	AT7
Standard rectangle	AT10
Standard oblong	AT13
Standard shapes	AT16
Shapes geometry	AT19

Additional

Alignment rings	AT22
Slitting tool 5 x 30	AT23
Slitting tool 5 x 56	AT25
Slitting tool 5 x 76,2	AT27
Slitting tool 5 x 56 with PU-stripper	AT29
Slitting tool 5 x 76,2 with PU-stripper	AT31
PU-strippers	AT33
Punch inserts	AT35
Die adapters and shims	AT36

Additional

Information	AT37
Grinding	AT38
Die clearance	AT39
Request form	AT40

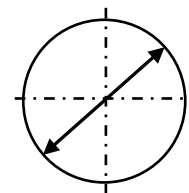
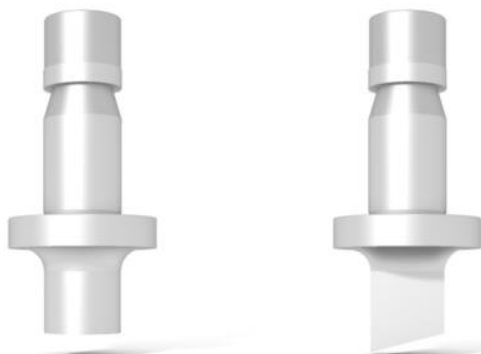

Type	Size (GR)	Diameter max., mm	Art. N.	Price, EUR
Punch flat	1	1,00-30,50	S1PRAF74	--

Punch whisper

1	1,00-30,50	S1PRAW77	--
---	------------	----------	----

* Standard flat 74 mm. Flat 77 mm is equal to S1PRAF74 with the use only by machines of Group 2

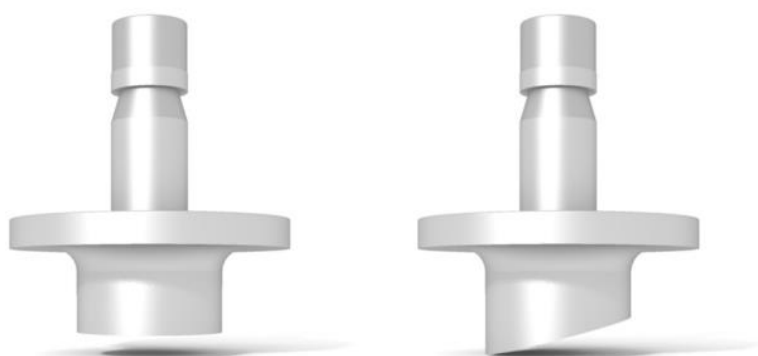

Type	Size (GR)	Diameter max., mm	Art. N.	Price, EUR
Punch flat	2	30,51-40,00	S2PRAF74	--
Punch flat	2	40,01-50,80	S2PRBF74	--
Punch flat	2	50,81-60,00	S2PRCF74	--
Punch flat	2	60,01-72,00	S2PRDF74	--
Punch flat	2	72,01-76,20	S2PREF74	--
Punch whisper	2	30,51-40,00	S2PRAW77	--
Punch whisper	2	40,01-50,80	S2PRBW77	--
Punch whisper	2	50,81-60,00	S2PRCW77	--
Punch whisper	2	60,01-72,00	S2PRDW77	--
Punch whisper	2	72,01-76,20	S2PREW77	--

* Standard flat 74 mm. Flat 77 mm is equal to S2PR_F74 with the use only by machines of Group 2

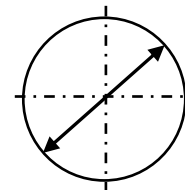

Type	Size (GR)	Diameter max., mm	Art. N.	Price, EUR
Punch reinforced flat	1	1,00-30,50	S1PRARFF74	--

Punch reinforced whisper

1	1,00-30,50	S1PRARFW77	--
---	------------	------------	----

* Standard flat 74 mm. Flat 77 mm is equal to S1PRARFF74 with the use only by machines of Group 2



Type	Size (GR)	Diameter max., mm	Art. N.	Price, EUR
Punch reinforced flat	2	30,51-40,00	S2PRARFF74	--
Punch reinforced flat	2	40,01-76,20	S2PRBRFF74	--
Punch reinforced whisper	2	30,51-40,00	S2PRARFW77	--

Punch reinforced whisper

2	40,01-76,20	S2PRBRFW77	--
---	-------------	------------	----

* Standard flat 74 mm. Flat 77 mm is equal to S2PR_RFF74 with the use only by machines of Group 2

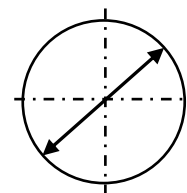

Type	Size (GR)	Diameter max., mm	Art. N.	Price, EUR
Stripper standard	2	1,00-78,00	S2SRA	--



Type	Size (GR)	Diameter max., mm	Art. N.	Price, EUR
HWS standard	1	1,00-32,00	S1DRA	--
HSS standard	1	1,00-32,00	S1DRAHSS	--
HWS reinforced	1	1,00-32,00	S1DRARF	--

* Die clearance distance is included in max. diameter size

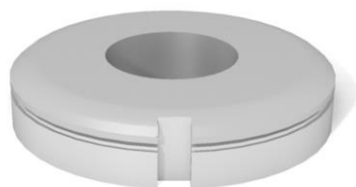

Type	Size (GR)	Diameter max., mm	Art. N.	Price, EUR
HWS standard	2	32,01-77,00	S2DRA	--
HSS standard	2	32,01-77,00	S2DRAHSS	--
HWS reinforced	2	32,01-42,00	S2DRARF	--
HWS reinforced	2	42,01-62,00	S2DRARF	--

* Die clearance distance is included in max. diameter size

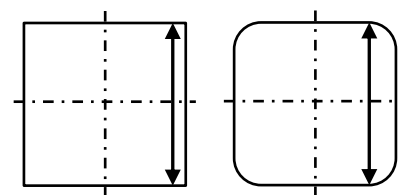

Type	Size (GR)	Side max., mm	Art. N.	Price, EUR
Punch flat	1	1,00-21,55	S1PSQAF74	--
Punch whisper	1	1,00-21,55	S1PSQAW77	--

* Standard flat 74 mm. Flat 77 mm is equal to S1PSQAF74 with the use only by machines of Group 2



Type	Size (GR)	Side max., mm	Art. N.	Price, EUR
Punch flat	2	21,56-28,25	S2PSQAF74	--
Punch flat	2	28,26-35,90	S2PSQBF74	--
Punch flat	2	35,91-42,40	S2PSQCF74	--
Punch flat	2	42,41-50,90	S2PSQDF74	--
Punch flat	2	50,91-53,90	S2PSQEF74	--
Punch whisper	2	21,56-28,25	S2PSQAW77	--
Punch whisper	2	28,26-35,90	S2PSQBW77	--
Punch whisper	2	35,91-42,40	S2PSQCW77	--
Punch whisper	2	42,41-50,90	S2PSQDW77	--
Punch whisper	2	50,91-53,90	S2PSQEW77	--

* Standard flat 74 mm. Flat 77 mm is equal to S2PSQ_F74 with the use only by machines of Group 2

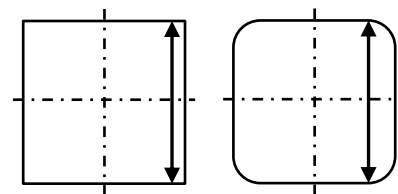

Type	Size (GR)	Side max., mm	Art. N.	Price, EUR
Punch reinforced flat	1	1,00-21,55	S1PSQARFF74	--
Punch reinforced whisper	1	1,00-21,55	S1PSQARFW77	--

* Standard flat 74 mm. Flat 77 mm is equal to S1PSQARFF74 with the use only by machines of Group 2



Type	Size (GR)	Side max., mm	Art. N.	Price, EUR
Punch reinforced flat	2	21,56-28,25	S2PSQARFF74	--
Punch reinforced flat	2	28,26-53,90	S2PSQBRFF74	--
Punch reinforced whisper	2	21,56-28,25	S2PSQARFW77	--
Punch reinforced whisper	2	28,26-53,90	S2PSQBRFW77	--

* Standard flat 74 mm. Flat 77 mm is equal to S2PSQ_RFF74 with the use only by machines of Group 2

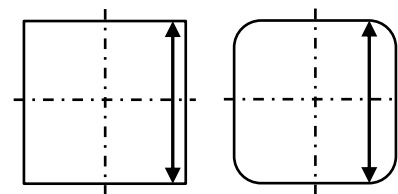

Type	Size (GR)	Side max., mm	Art. N.	Price, EUR
Stripper standard	2	1,00-56,00	S2SSQA	--



Type	Size (GR)	Side max., mm	Art. N.	Price, EUR
HWS standard	1	1,00-22,50	S1DSQA	--
HSS standard	1	1,00-22,50	S1DSQAHSS	--
HWS reinforced	1	1,00-22,50	S1DSQARF	--

* Die clearance distance is included in max. diameter size

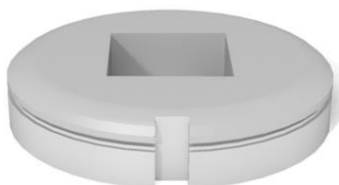

Type	Size (GR)	Side max., mm	Art. N.	Price, EUR
HWS standard	2	22,51-54,90	S2DSQA	--
HSS standard	2	22,51-54,90	S2DSQAHSS	--
HWS reinforced	2	22,51-30,20	S2DSQARF	--
HWS reinforced	2	30,21-43,00	S2DSQARF	--

* Die clearance distance is included in max. diameter size

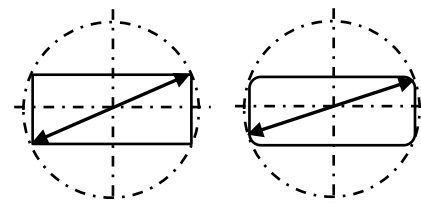

Type	Size (GR)	Diagonal max., mm	Art. N.	Price, EUR
Punch flat	1	1,00-30,50	S1PRTAF74	--

Punch whisper

1

1,00-30,50

S1PRTAW77

--

* Standard flat 74 mm. Flat 77 mm is equal to S1PRTAF74 with the use only by machines of Group 2

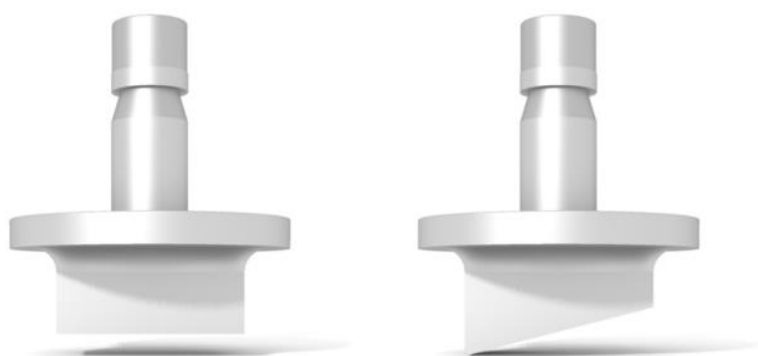

Type	Size (GR)	Diagonal max., mm	Art. N.	Price, EUR
Punch flat	2	30,51-40,00	S2PRTAF74	--

Punch flat

2

40,01-50,80

S2PRTBF74

--

Punch flat

2

50,81-60,00

S2PRTC74

--

Punch flat

2

60,01-72,00

S2PRTDF74

--

Punch flat

2

72,01-76,20

S2PRTEF74

--

Punch whisper

2

30,51-40,00

S2PRTAW77

--

Punch whisper

2

40,01-50,80

S2PRTBW77

--

Punch whisper

2

50,81-60,00

S2PRTCW77

--

Punch whisper

2

60,01-72,00

S2PRTDW77

--

Punch whisper

2

72,01-76,20

S2PRTEW77

--

* Standard flat 74 mm. Flat 77 mm is equal to S2PRT_F74 with the use only by machines of Group 2

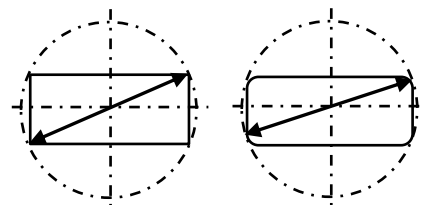

Type	Size (GR)	Diagonal max., mm	Art. N.	Price, EUR
Punch reinforced flat	1	1,00-30,50	S1PRTARFF74	--
Punch reinforced whisper	1	1,00-30,50	S1PRTARFW77	--

* Standard flat 74 mm. Flat 77 mm is equal to S1PRTARFF74 with the use only by machines of Group 2



Type	Size (GR)	Diagonal max., mm	Art. N.	Price, EUR
Punch reinforced flat	2	30,51-40,00	S2PRTARFF74	--
Punch reinforced flat	2	40,01-76,20	S2PRTBRFF74	--
Punch reinforced whisper	2	30,51-40,00	S2PRTARFW77	--
Punch reinforced whisper	2	40,01-76,20	S2PRTBRFW77	--

* Standard flat 74 mm. Flat 77 mm is equal to S2PRT_RFF74 with the use only by machines of Group 2

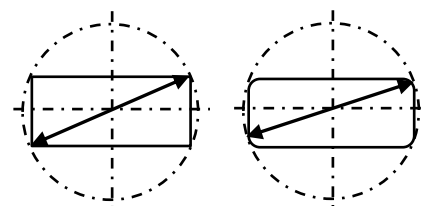

Type	Size (GR)	Diagonal max., mm	Art. N.	Price, EUR
Stripper standard	2	1,00-78,00	S2SRTA	--



Type	Size (GR)	Diagonal max., mm	Art. N.	Price, EUR
HWS standard	1	1,00-32,00	S1DRTA	--
HSS standard	1	1,00-32,00	S1DRTAHSS	--
HWS reinforced	1	1,00-32,00	S1DRTARF	--

* Die clearance distance is included in max. diameter size

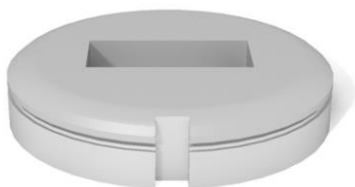

Type	Size (GR)	Diagonal max., mm	Art. N.	Price, EUR
HWS standard	2	32,01-77,00	S2DRTA	--
HSS standard	2	32,01-77,00	S2DRTAHSS	--
HWS reinforced	2	32,01-42,00	S2DRTARF	--
HWS reinforced	2	42,01-62,00	S2DRTARF	--

* Die clearance distance is included in max. diameter size

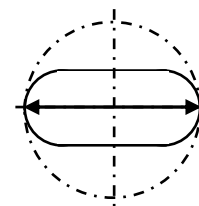

Type	Size (GR)	Diagonal max., mm	Art. N.	Price, EUR
Punch flat	1	1,00-30,50	S1POBAF74	--
Punch whisper	1	1,00-30,50	S1POBAW77	--

* Standard flat 74 mm. Flat 77 mm is equal to S1POBAF74 with the use only by machines of Group 2



Type	Size (GR)	Diagonal max., mm	Art. N.	Price, EUR
Punch flat	2	30,51-40,00	S2POBAF74	--
Punch flat	2	40,01-50,80	S2POBBF74	--
Punch flat	2	50,81-60,00	S2POBCF74	--
Punch flat	2	60,01-72,00	S2POBDF74	--
Punch flat	2	72,01-76,20	S2POBEF74	--
Punch whisper	2	30,51-40,00	S2POBAW77	--
Punch whisper	2	40,01-50,80	S2POBBW77	--
Punch whisper	2	50,81-60,00	S2POBCW77	--
Punch whisper	2	60,01-72,00	S2POBDW77	--
Punch whisper	2	72,01-76,20	S2POBEW77	--

* Standard flat 74 mm. Flat 77 mm is equal to S2POB_F74 with the use only by machines of Group 2

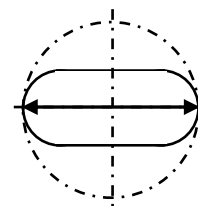

Type	Size (GR)	Diagonal max., mm	Art. N.	Price, EUR
Punch reinforced flat	1	1,00-30,50	S1POBARFF74	--
Punch reinforced whisper	1	1,00-30,50	S1POBARFW77	--

* Standard flat 74 mm. Flat 77 mm is equal to S1POBARFF74 with the use only by machines of Group 2



Type	Size (GR)	Diagonal max., mm	Art. N.	Price, EUR
Punch reinforced flat	2	30,51-40,00	S2POBARFF74	--
Punch reinforced flat	2	40,01-76,20	S2POBBRFF74	--
Punch reinforced whisper	2	30,51-40,00	S2POBARFW77	--
Punch reinforced whisper	2	40,01-76,20	S2POBBRFW77	--

* Standard flat 74 mm. Flat 77 mm is equal to S2POB_RFF74 with the use only by machines of Group 2

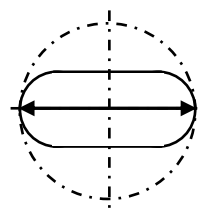

Type	Size (GR)	Diagonal max., mm	Art. N.	Price, EUR
Stripper standard	2	1,00-78,00	S2SOBA	--

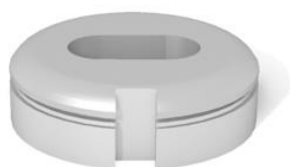

Type	Size (GR)	Diagonal max., mm	Art. N.	Price, EUR
HWS standard	1	1,00-32,00	S1DOBA	--
HSS standard	1	1,00-32,00	S1DOBAHSS	--
HWS reinforced	1	1,00-32,00	S1DOBARF	--

* Die clearance distance is included in max. diameter size

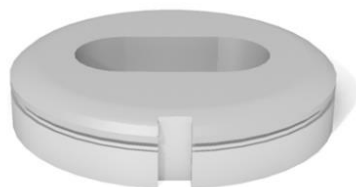

Type	Size (GR)	Diagonal max., mm	Art. N.	Price, EUR
HWS standard	2	32,01-77,00	S2DOBA	--
HSS standard	2	32,01-77,00	S2DOBAHSS	--
HWS reinforced	2	32,01-42,00	S2DOBARF	--
HWS reinforced	2	42,01-62,00	S2DOBARF	--

* Die clearance distance is included in max. diameter size

Standard shapes are indicated on page AT19 (Standard shapes Group 1)

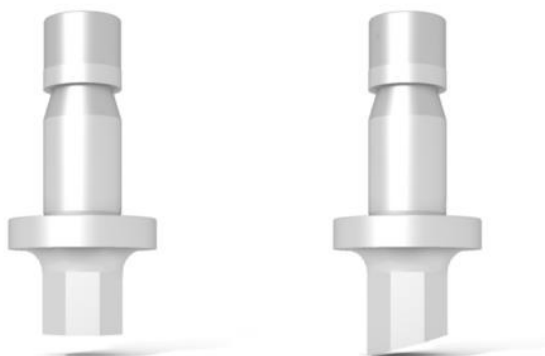

Type	Size (GR)	Diagonal max., mm	Art. N.	Price, EUR
Punch flat	1	1,00-30,50	S1PSHAF74	--
Punch whisper	1	1,00-30,50	S1PSHAW77	--

* Standard flat 74 mm. Flat 77 mm is equal to S1PSHAF74 with the use only by machines of Group 2

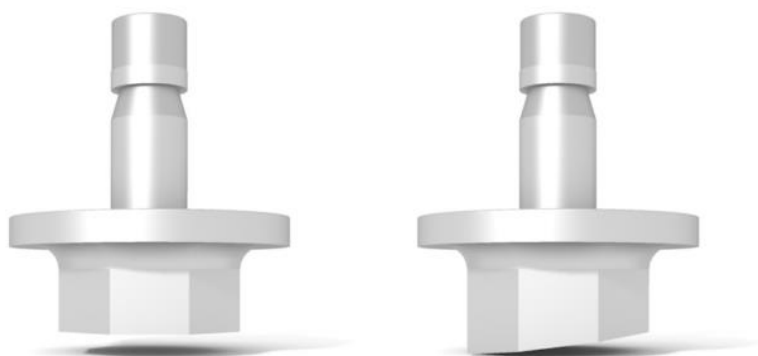

Type	Size (GR)	Diagonal max., mm	Art. N.	Price, EUR
Punch flat	2	30,51-40,00	S2PSHAF74	--
Punch flat	2	40,01-50,80	S2PSHBF74	--
Punch flat	2	50,81-60,00	S2PSHCF74	--
Punch flat	2	60,01-72,00	S2PSHDF74	--
Punch flat	2	72,01-76,20	S2PSHEF74	--
Punch whisper	2	30,51-40,00	S2PSHAW77	--
Punch whisper	2	40,01-50,80	S2PSHBW77	--
Punch whisper	2	50,81-60,00	S2PSHCW77	--
Punch whisper	2	60,01-72,00	S2PSHDW77	--
Punch whisper	2	72,01-76,20	S2PSHEW77	--

* Standard flat 74 mm. Flat 77 mm is equal to S2PSH_F74 with the use only by machines of Group 2

Standard shapes are indicated on page AT19 (Standard shapes Group 1)



Type	Size (GR)	Diagonal max., mm	Art. N.	Price, EUR
Punch reinforced flat	1	1,00-30,50	S1PSHARFF74	--
Punch reinforced whisper	1	1,00-30,50	S1PSHARFW77	--

* Standard flat 74 mm. Flat 77 mm is equal to S1PSHARFF74 with the use only by machines of Group 2



Type	Size (GR)	Diagonal max., mm	Art. N.	Price, EUR
Punch reinforced flat	2	30,51-40,00	S2PSHARFF74	--
Punch reinforced flat	2	40,01-76,20	S2PSHBRFF74	--
Punch reinforced whisper	2	30,51-40,00	S2PSHARFW77	--
Punch reinforced whisper	2	40,01-76,20	S2PSHBRFW77	--

* Standard flat 74 mm. Flat 77 mm is equal to S2PSH_RFF74 with the use only by machines of Group 2

Standard shapes are indicated on page AT19 (Standard shapes Group 1)



Type	Size (GR)	Diagonal max., mm	Art. N.	Price, EUR
Stripper standard	2	1,00-78,00	S2SSHA	--

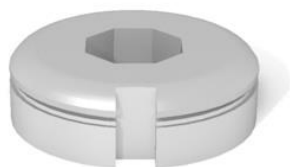

Type	Size (GR)	Diagonal max., mm	Art. N.	Price, EUR
HWS standard	1	1,00-32,00	S1DSHA	--
HSS standard	1	1,00-32,00	S1DSHAHSS	--
HWS reinforced	1	1,00-32,00	S1DSHARF	--

* Die clearance distance is included in max. diameter size

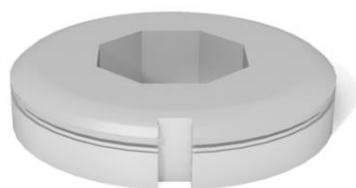

Type	Size (GR)	Diagonal max., mm	Art. N.	Price, EUR
HWS standard	2	32,01-77,00	S2DSHA	--
HSS standard	2	32,01-77,00	S2DSHAHSS	--
HWS reinforced	2	32,01-42,00	S2DSHARF	--
HWS reinforced	2	42,01-62,00	S2DSHARF	--

* Die clearance distance is included in max. diameter size

Standard shapes Group 1:

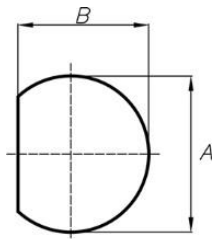

S42

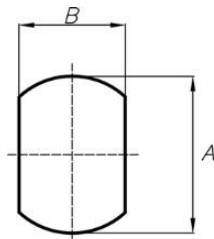

S43

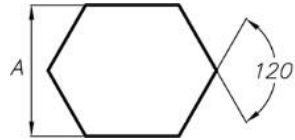

S09

Special shapes Group 1:

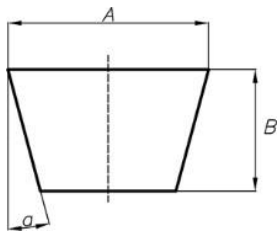

S03

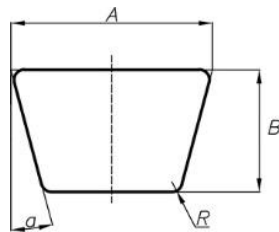

S04

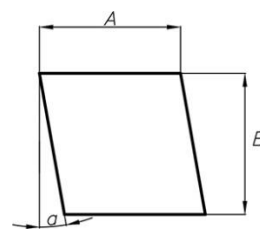

S11

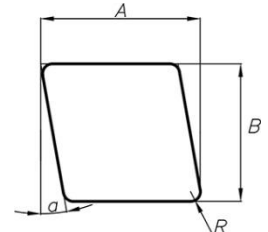

S12

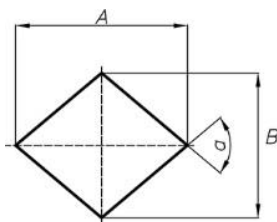

S13

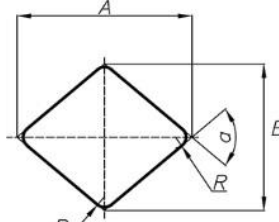

S14

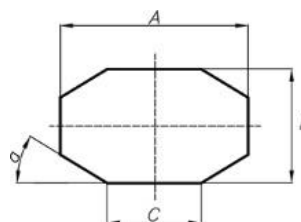

S15

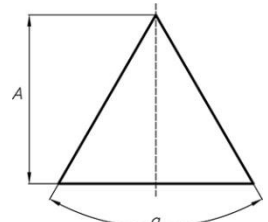

S16

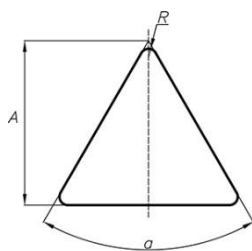

S17

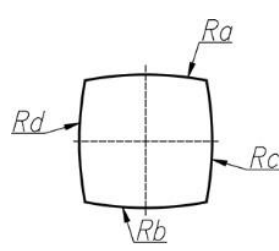

S25

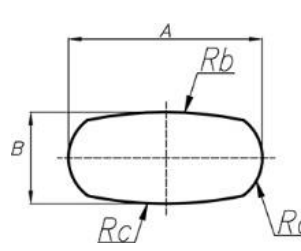

S30

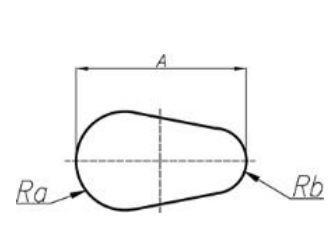

S31

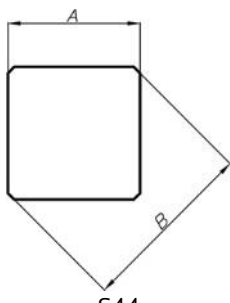

S44

Special shapes Group 2:

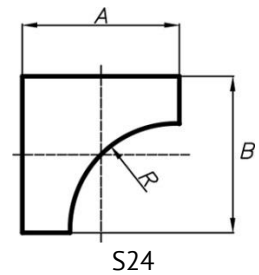
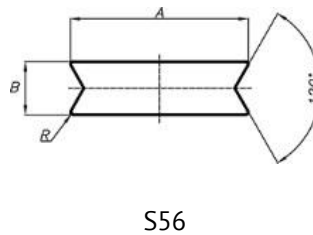
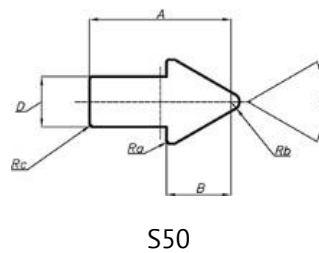
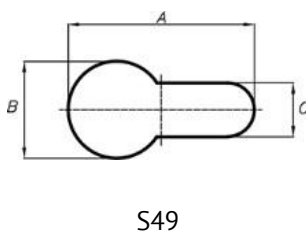
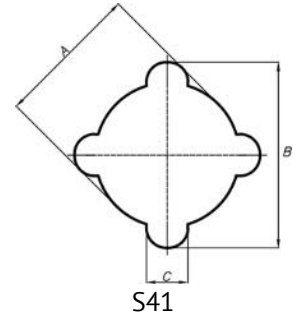
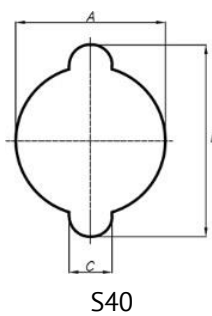
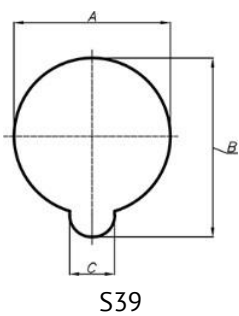
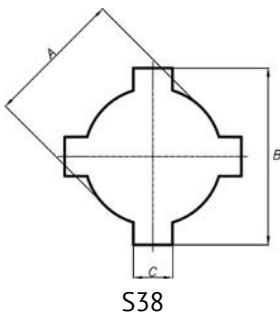
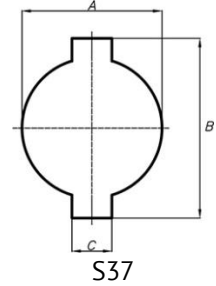
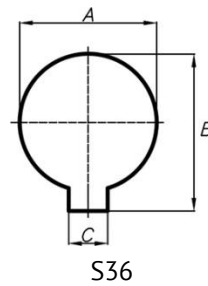
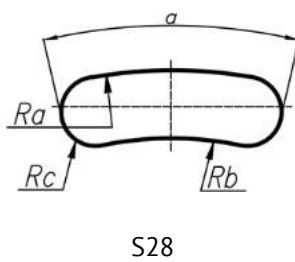
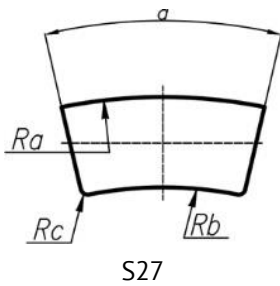
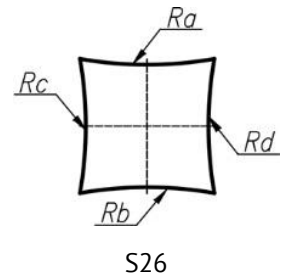
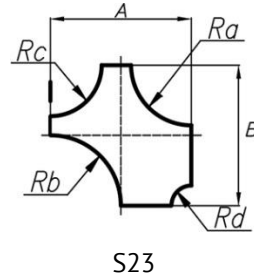
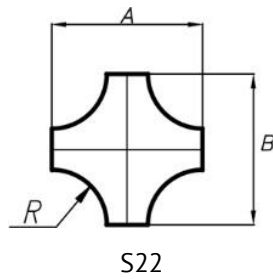
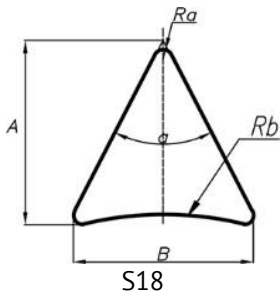
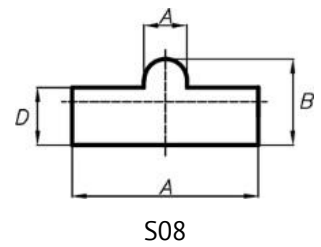
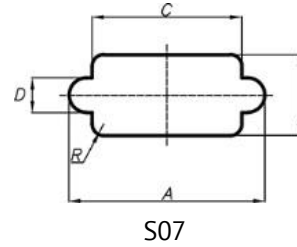
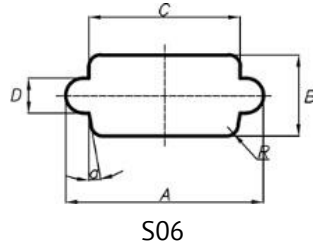
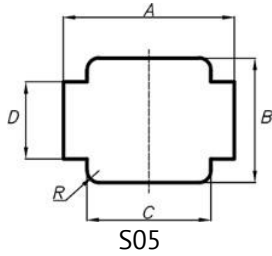

Special shapes Group 3:

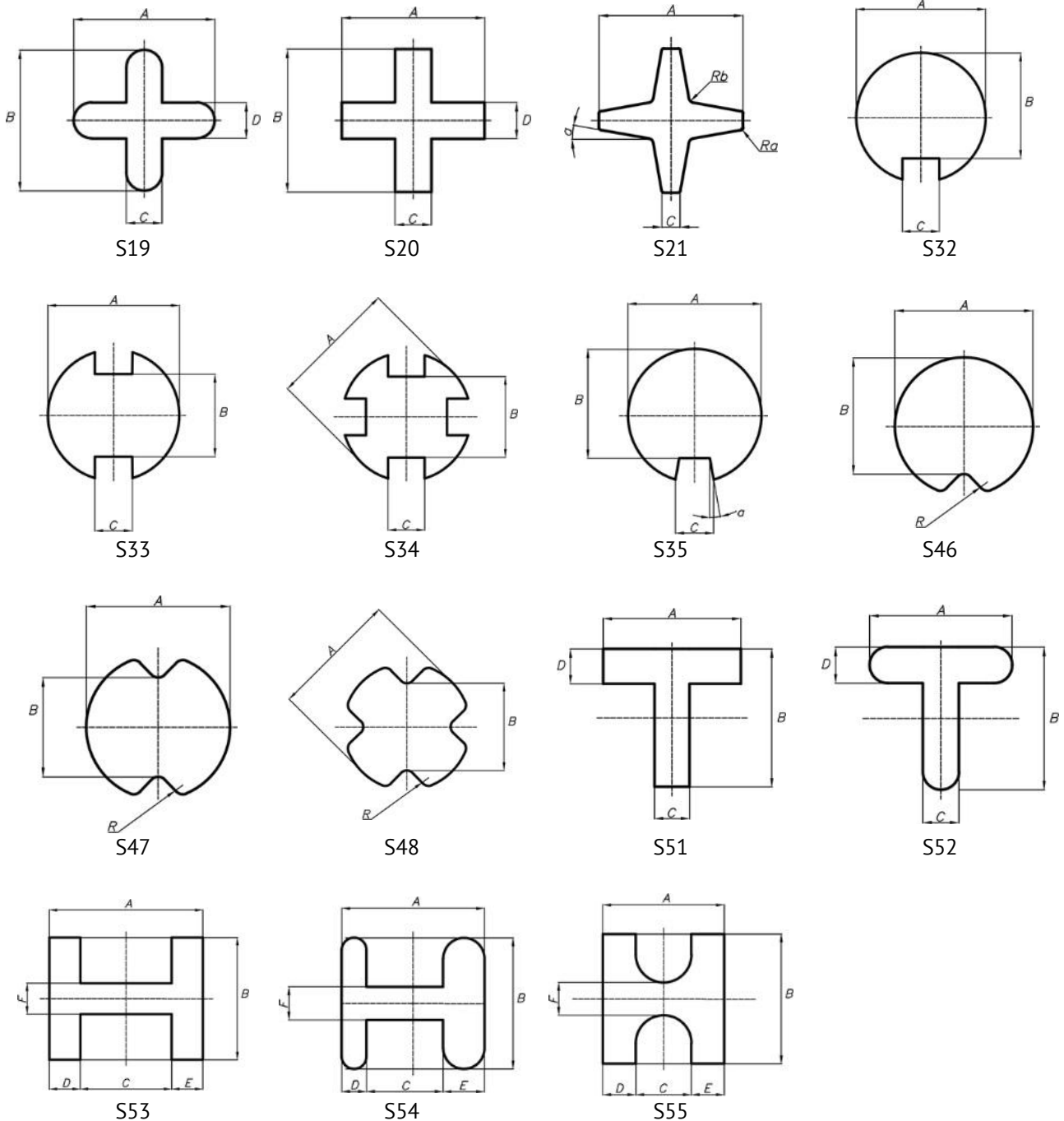

* Any other geometry could be offered under request and providing of drawing with all necessary sizes

Alignment rings

for automatic tool change

TRUMPF STYLE

for automatic punching machines

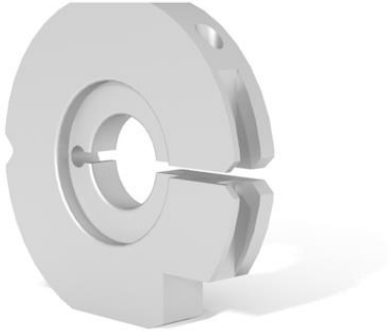

Type	Size (GR)	Art. N.	Price, EUR
Standard with cut out*	1	S1AR6T	--

* Alignment key is included

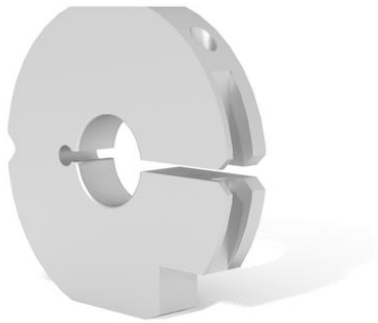

Type	Size (GR)	Art. N.	Price, EUR
Standard without cut out*	2	S2AR6T	--

* Alignment key is included

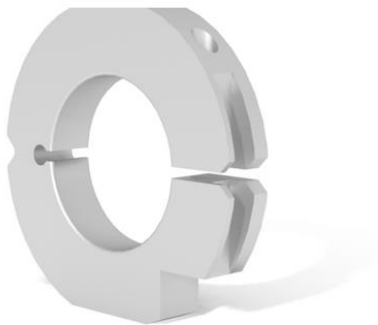

Type	Size (GR)	Art. N.	Price, EUR
Ring for reinforcement punches	1/2	AR6TRF	--

* Alignment key is included

Slitting tools

Size: 5 x 30 mm; Size (Gr) 2

TRUMPF STYLE
for automatic punching machines

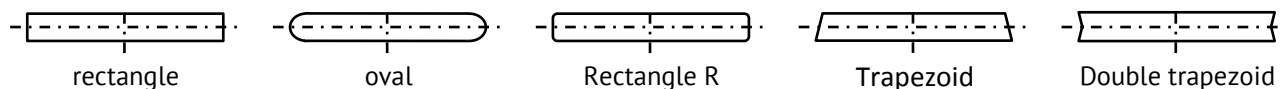

Type	Art. N.	Price, EUR
Complete tool assemble including punch holder, screws, punch insert, stripper, die insert, die holder		
- Standard rectangle	SLT30RTASSY	--
- Rectangle with R 0,5	SLT30RRASSY	--
- Standard oval	SLT30OBASSY	--
- Trapezoid for microjoints	SLT30TRASSY	--
- Double trapezoid	SLT30DTRASSY	--

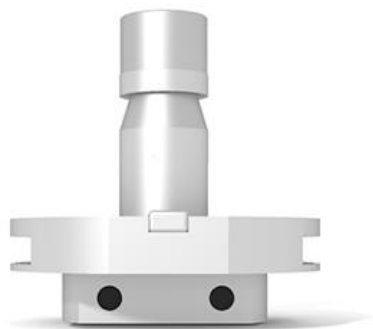

Type	Art. N.	Price, EUR
Tool holder completed with integrated alignment ring and screws	SLTPH	--
Set of screws M8 x 16 (2 pcs)	SLTPH_SCR	--



Type	Art. N.	Price, EUR
Punch insert		
- Standard rectangle	SLT30PIRT	--
- Rectangle with R 0,5	SLT30PIRR	--
- Standard oval	SLT30PIOB	--
- Trapezoid for microjoints	SLT30PITR	--
- Double trapezoid	SLT30PIDTR	--

Slitting tools

Size: 5 x 30 mm; Size (Gr) 2

TRUMPF STYLE

for automatic punching machines

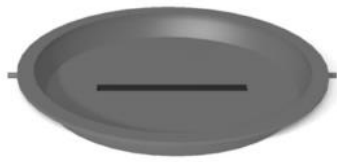

Type	Art. N.	Price, EUR
Slitting stripper		
- Standard rectangle	SLT30STRRT	--
- Rectangle with R 0,5	SLT30STRRR	--
- Standard oval	SLT30STROB	--
- Trapezoid for microjoints	SLT30STRTR	--
- Double trapezoid	SLT30STRDTR	--



Type	Art. N.	Price, EUR
Die insert		
- Standard rectangle	SLT30DIRT	--
- Rectangle with R 0,5	SLT30DIRR	--
- Standard oval	SLT30DIOB	--
- Trapezoid for microjoints	SLT30DITR	--
- Double trapezoid	SLT30DIDTR	--

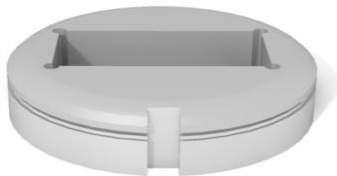

Type	Art. N.	Price, EUR
Die adapter for die insert (Compatible for die inserts 5x30; 5x56)	SLTDA56	--

Slitting tools

Size: 5 x 56 mm; Size (Gr) 2

TRUMPF STYLE
for automatic punching machines

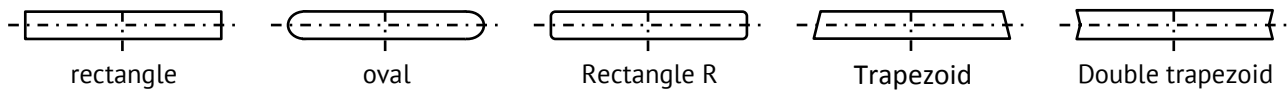

Type	Art. N.	Price, EUR
Complete tool assemble including punch holder, screws, punch insert, stripper, die insert, die holder		
- Standard rectangle	SLT56RTASSY	--
- Rectangle with R 0,5	SLT56RRASSY	--
- Standard oval	SLT56OBASSY	--
- Trapezoid for microjoints	SLT56TRASSY	--
- Double trapezoid	SLT56DTRASSY	--

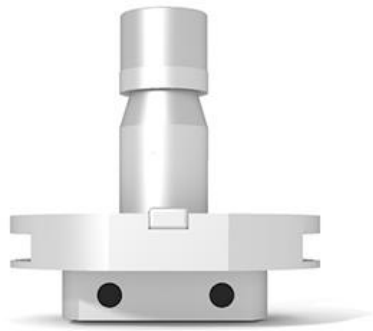

Type	Art. N.	Price, EUR
Tool holder completed with integrated alignment ring and screws	SLTPH	--
Set of screws M8 x 16 (2 pcs)	SLTPH_SCR	--



Type	Art. N.	Price, EUR
Punch insert		
- Standard rectangle	SLT56PIRT	--
- Rectangle with R 0,5	SLT56PIRR	--
- Standard oval	SLT56PIOB	--
- Trapezoid for microjoints	SLT56PITR	--
- Double trapezoid	SLT56PIDTR	--

Slitting tools

Size: 5 x 56 mm; Size (Gr) 2

TRUMPF STYLE

for automatic punching machines

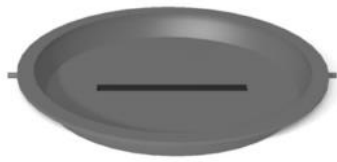

Type	Art. N.	Price, EUR
Slitting stripper		
- Standard rectangle	SLT56STRRT	--
- Rectangle with R 0,5	SLT56STRRR	--
- Standard oval	SLT56STROB	--
- Trapezoid for microjoints	SLT56STRTR	--
- Double trapezoid	SLT56STRDTR	--



Type	Art. N.	Price, EUR
Die insert		
- Standard rectangle	SLT56DIRT	--
- Rectangle with R 0,5	SLT56DIRR	--
- Standard oval	SLT56DIOB	--
- Trapezoid for microjoints	SLT56DITR	--
- Double trapezoid	SLT56DIDTR	--

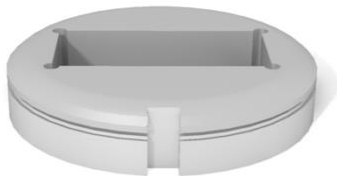

Type	Art. N.	Price, EUR
Die adapter for die insert (Compatible for die inserts 5x30; 5x56)	SLTDA56	--

Slitting tools

Size: 5 x 76,2 mm; Size (Gr) 2

TRUMPF STYLE

for automatic punching machines

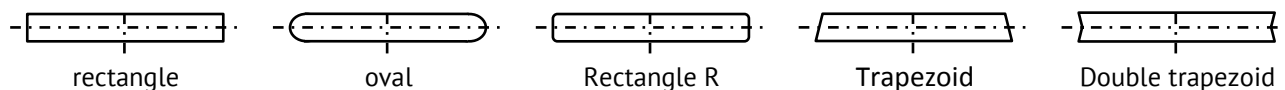

Type	Art. N.	Price, EUR
Complete tool assemble including punch holder, screws, punch insert, stripper, die insert, die holder		
- Standard rectangle	SLT76RTASSY	--
- Rectangle with R 0,5	SLT76RRASSY	--
- Standard oval	SLT76OBASSY	--
- Trapezoid for microjoints	SLT76TRASSY	--
- Double trapezoid	SLT76DTRASSY	--

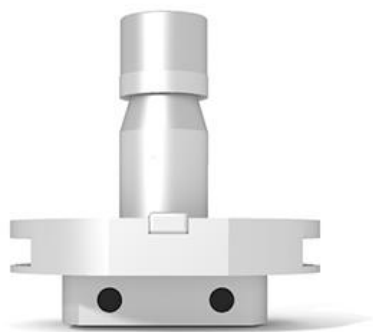

Type	Art. N.	Price, EUR
Tool holder completed with integrated alignment ring and screws	SLTPH	--
Set of screws M8 x 16 (2 pcs)	SLTPH_SCR	--



Type	Art. N.	Price, EUR
Punch insert		
- Standard rectangle	SLT76PIRT	--
- Rectangle with R 0,5	SLT76PIRR	--
- Standard oval	SLT76PIOB	--
- Trapezoid for microjoints	SLT76PITR	--

Slitting tools

Size: 5 x 76,2 mm; Size (Gr) 2

TRUMPF STYLE

for automatic punching machines

- Double trapezoid

SLT76PIDTR

--

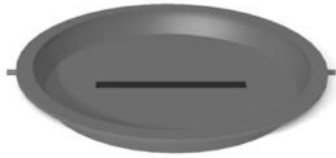

Type	Art. N.	Price, EUR
Slitting stripper		
- Standard rectangle	SLT76STRRT	--
- Rectangle with R 0,5	SLT76STRRR	--
- Standard oval	SLT76STROB	--
- Trapezoid for microjoints	SLT76STRTR	--
- Double trapezoid	SLT76STRDTR	--



Type	Art. N.	Price, EUR
Die insert		
- Standard rectangle	SLT76DIRT	--
- Rectangle with R 0,5	SLT76DIRR	--
- Standard oval	SLT76DIOB	--
- Trapezoid for microjoints	SLT76DITR	--
- Double trapezoid	SLT76DIDTR	--



Type	Art. N.	Price, EUR
Die adapter for die insert	SLTDA76	--

Slitting tools

Size: 5 x 56 mm with PU-stripper

TRUMPF STYLE
for automatic punching machines

Slitting tools with PU-stripper are normally used to make cutting near formings

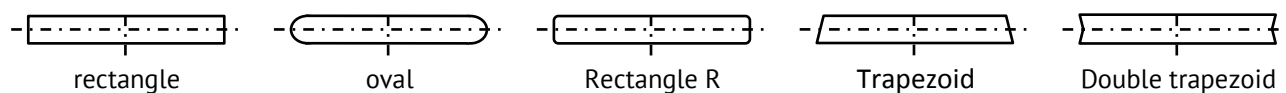

Type	Art. N.	Price, EUR
Complete tool assemble including punch holder, screws, punch insert, stripper, die insert, die holder		
- Standard rectangle	SLPU56RTASSY	--
- Rectangle with R 0,5	SLPU56RRASSY	--
- Standard oval	SLPU56OBASSY	--
- Trapezoid for microjoints	SLPU56TRASSY	--
- Double trapezoid	SLPU56DTRASSY	--



Type	Art. N.	Price, EUR
Upper tool completed with springs and screws		
- Standard rectangle	SLPU56RTTH	--
- Rectangle with R 0,5	SLPU56RRTH	--
- Standard oval	SLPU56OBTH	--
- Trapezoid for microjoints	SLPU56TRTH	--
- Double trapezoid	SLPU56DTRTH	--
Punch only without springs and screws	SLPU56_PO	--
PU-springs and bushings (2 pcs)	SLPU56_SPRB	--
Set of screws (2 pcs)	SLPU56_SCR	--

Slitting tools

Size: 5 x 56 mm with PU-stripper

TRUMPF STYLE
for automatic punching machines



Type	Art. N.	Price, EUR
Die insert		
- Standard rectangle	SLT56DIRT	--
- Rectangle with R 0,5	SLT56DIRR	--
- Standard oval	SLT56DIOB	--
- Trapezoid for microjoints	SLT56DITR	--
- Double trapezoid	SLT56DIDTR	--

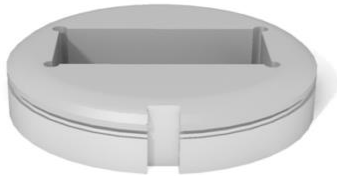

Type	Art. N.	Price, EUR
Die adapter for die insert (Compatible for die inserts 5x30; 5x56)	SLTDA56	--

Slitting tools

Size: 5 x 76,2 mm with PU-stripper

TRUMPF STYLE
for automatic punching machines

Slitting tools with PU-stripper are normally used to make cutting near formings

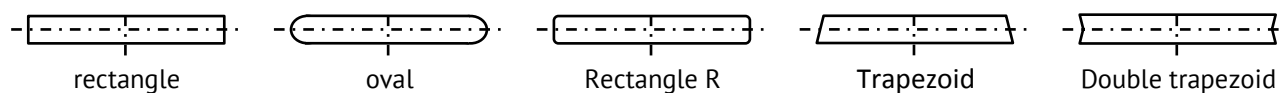

Type	Art. N.	Price, EUR
Complete tool assemble including punch holder, screws, punch insert, stripper, die insert, die holder		
- Standard rectangle	SLPU76RTASSY	--
- Rectangle with R 0,5	SLPU76RRASSY	--
- Standard oval	SLPU76OBASSY	--
- Trapezoid for microjoints	SLPU76TRASSY	--
- Double trapezoid	SLPU76DTRASSY	--



Type	Art. N.	Price, EUR
Upper tool completed with springs and screws		
- Standard rectangle	SLPU76RTTH	--
- Rectangle with R 0,5	SLPU76RRTH	--
- Standard oval	SLPU76OBTH	--
- Trapezoid for microjoints	SLPU76TRTH	--
- Double trapezoid	SLPU76DTRTH	--
Punch only without springs and screws	SLPU76_PO	--
PU-springs and bushings (2 pcs)	SLPU76_SPRB	--
Set of screws (2 pcs)	SLPU76_SCR	--

Slitting tools

Size: 5 x 76,2 mm with PU-stripper

TRUMPF STYLE

for automatic punching machines



Type	Art. N.	Price, EUR
Die insert		
- Standard rectangle	SLT76DIRT	--
- Rectangle with R 0,5	SLT76DIRR	--
- Standard oval	SLT76DIOB	--
- Trapezoid for microjoints	SLT76DITR	--
- Double trapezoid	SLT76DIDTR	--



Type	Art. N.	Price, EUR
Die adapter for die insert	SLTDA76	--

PU-Strippers replace normal strippers and used for punching near formings. Also punching with PU-stripper helps to reduce noise during punching process.



Type	Diagonal max., mm	Height, mm	Art. N.	Price, EUR
PU-stripper for flat punches (Ø 30 mm)	12	19		
- Standard blank			SPU1FLA	--
- Round			SPU1FLB	--
- Shape			SPU1FLC	--
PU-stripper for whisper punches (Ø 30 mm)	12	22		
- Standard blank			SPU1WHA	--
- Round			SPU1WHB	--
- Shape			SPU1WHC	--



Type	Diagonal max., mm	Height, mm	Art. N.	Price, EUR
PU-stripper for flat punches (Ø 60 mm)	30,50	25		
- Standard blank			SPU2FLA	--
- Round			SPU2FLB	--
- Shape			SPU2FLC	--
PU-stripper for whisper punches (Ø 60 mm)	30,50	28		
- Standard blank			SPU2WHA	--
- Round			SPU2WHB	--
- Shape			SPU2WHC	--



Type	Diagonal max., mm	Height, mm	Art. N.	Price, EUR
PU-stripper for flat punches (Ø 30 mm)	12	19		
- Standard blank			SPU3FLA	--
- Round			SPU3FLB	--
- Shape			SPU3FLC	--
PU-stripper for whisper punches (Ø 30 mm)	12	22		
- Standard blank			SPU3WHA	--
- Round			SPU3WHB	--
- Shape			SPU3WHC	--

Punch chucks make able to replace only punch inserts for Size 1 (Gr1) tooling for small dimensions of hole.



Type	Size (GR)	Art. N.	Price, EUR
Punch chuck for 0/A inserts	1	PUIPH0A	--
Punch chuck for 0/B inserts	1	PUIPH0B	--



Type	Size (GR)	Diagonal size, mm	Art. N.	Price, EUR
Punch insert round	0/A	1,00-6,00	PUI0AR	--
Punch insert shape	0/B	1,00-6,00	PUI0ASH	--



Type	Size (GR)	Diagonal size, mm	Art. N.	Price, EUR
Punch insert round	0/B	1,00-6,00	PUI0BRSM	--
Punch insert shape	0/B	1,00-6,00	PUI0BSHSM	--
Punch insert round	0/B	6,01-10,50	PUI0BR	--
Punch insert shape	0/B	6,01-10,50	PUI0BSH	--

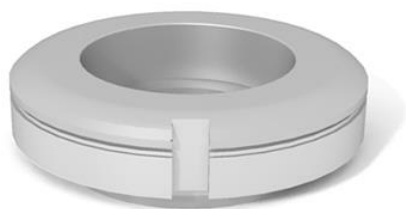

Type	Size (GR)	Art. N.	Price, EUR
Standard adapter for Size 1 dies	2>1	ADDIE1	--



Type	Size (GR)	Art. N.	Price, EUR
Brush adapter for Size 1 dies	2>1	ADDIE2	--
Spare brush for brush adapter		ADDIE2B	--
Shim for brush		ADDIE2C	--



Type	Size (GR)	Art. N.	Price, EUR
Die shims (6 pcs in set)*	1	DIESHIM1	--

Thickness 0,1; 0,3; 0,5 mm available all all thicknesses x 2 pcs in 1 set



Type	Size (GR)	Art. N.	Price, EUR
Die shims (6 pcs in set)*	2	DIESHIM2	--

Thickness 0,1; 0,3; 0,5 mm available all all thicknesses x 2 pcs in 1 set

TRUMPF®, TRUMATIC, TRUMATIC, TRUPUNCH, ROTATION – are trademarks of Trumpf GmbH + Co. KG. These trademarks are used in this catalog only for the identification of machines models without any other purpose of use.

All the tools are manufactured with the highest standards in manufacturing process and the materials to be used to achieve the best quality of tooling.

Pictures, used at the present catalog are prepared for the visual identification of tooling and could have differences to the real supply tools. In this way pictures can't be used as 100% tooling conformity. Please do not hesitate to contact us if you have any doubts or questions for the best proper identification.

Main design, images and other information of the present document is the subject of copyright. Users are free to use any information from the present document for non-commercial purposes with the use of the correct reference connected to the source of used information. All other use of the published information is forbidden and requires the written approval of the Company in advance before the use of the information.

If prices are indicated at the present document, they are understandable with the conditions of shipment: ExWorks (incoterms 2010), Milano, Italia. The Company reserves the right of the shipment from other area or city of Italy under the same conditions. All the information could be found under the link <http://www.precitools.it/en/salecond.htm>

Please be informed that the version of document including prices (pricelist) is available only dealers and distributors and subject to commercial secret.

Any technical information, tables, formulas and charts have a nature of general recommendation and could be different based on various sources and parameters, such as material specification, tool which is used machine type etc. In this case all the information can't be understandable as the direct solution for your technical process.

The company holds the rights to replace, edit, modify and change any position of the present document without prior notification. The price and/or Article number is valid based on the detailed quotation. The information, indicated in the present document could not be understandable as the offer or any obligation of sale.

We are at your disposal to offer:

- Punching tools of TRUMPF style for manual and keyed automatic (not Rotation) TRUMPF machines and other trademarks;
- Punching tools of THICK TURRET system;
- Bending tools of PROMECAM system for press brakes;
- Bending tools of TRUMPF-WILA system for press brakes.

The main purpose for special grinding of the punch shape is the possibility to reduce the punching force, necessary to obtain the punch hole and more effective material cutting during the process. We are able to execute any special grinding of punch, which could be important to use the big shape tooling with big thicknesses of the sheet.

Additional advantages for special grinding could be:

- Noise reduction up to 50%;
- Less or elimination of burrs;
- Easy of punch extraction;
- Reduction of machine vibrations



Whisper grinding

- Easy to regrind
- To use for any size
- Fast resharpening time



Whisper grinding with flat

- Easy to regrind
- To use for any size



Double whisper

- Easy to regrind
- To use for any size
- Optimal to reduce punching force
- Fast resharpening time



Negative whisper

- Hard to regrind
- To use for big sizes
- To use for slim countours



Tooths grinding

- Hard to regrind
- To use for long shapes with the risk of deformation
- Fast resharpening time



4 parts grinding

- Very hard to regrind
- Used only for square or square shapes
- To use for big sizes

Die clearance is very important to save the necessary space for the deformed metal during the hit. This table is only the general reference, for the sharp dimensions please consult to your technical office based on precision material parameters.

Material Thickness, mm	Die clearance, mm			
	Mild steel	Stainless Steel	Aluminum	Copper
0,8	0,15-0,20	0,20-0,24	0,15-0,16	0,15-0,16
1,0	0,20-0,25	0,25-0,30	0,15-0,20	0,15-0,20
1,5	0,30-0,38	0,37-0,45	0,22-0,30	0,22-0,30
2,0	0,40-0,50	0,50-0,60	0,30-0,40	0,30-0,40
2,5	0,50-0,60	0,62-0,75	0,37-0,50	0,37-0,50
3,0	0,60-0,75	0,75-0,90	0,45-0,60	0,45-0,60
3,2	0,64-0,80	0,80-0,96	0,48-0,64	0,48-0,64
3,5	0,70-0,88	0,88-1,05	0,53-0,70	0,53-0,70
4,0	0,80-1,00	1,00-1,20	0,60-0,80	0,60-0,80
4,5	0,90-1,13	1,13-1,35	0,68-0,90	0,68-0,90
5,0	1,00-1,25	--	0,75-1,00	0,75-1,00
5,5	1,10-1,38	--	0,83-1,10	0,83-1,10
6,0	1,20-1,50	--	0,90-1,20	0,90-1,20

To save the time please use the following request form to get the quick price offer for your Trumpf tools:

To PRECITOOLS SRLS
Via B. Crespi, 19 – MAC 4 – 4°Piano
20159 Milano, Italia

Tool offer request

Customer Name	
---------------	--

Machine model	
---------------	--

Customer address	
------------------	--

Delivery address	Or indicate ExWorks if shipment from production
------------------	---

Pos.	Part art. N	Shape	Dimensions	Size	Standard / Whisper / Grinding
1					
2					
3					
4					
5					
6					
7					
8					
9					
10					
11					
12					

* Please indicate other important information, for example what tool do you use now to be sure about compatibility.

You can specify article numbers from catalogs of other manufacturers to provide to you the competitive offer.

** To request dies offer please indicate the total size which contains: hole size + die clearance